

# CASSEL

## METAL SHARK® GF compact

Free falling powder and bulk products  
Low assembly height

Pipe Ø 100–300 mm/4–12 inch

### METAL SHARK® – The new generation in metal detecting technology

Introducing the METAL SHARK® presenting a completely new design in high sensitivity metal detectors. The METAL SHARK® provides outstanding sensitivity, accuracy, stability and precision product-effect-compensation.

The METAL SHARK® features the latest four channel DDS (direct digital synthesizer) and DSP (digital signal processor) technology. These technologies provide outstanding product-effect compensation. High processing speed, DDS and DSP makes the METAL SHARK® the leader in digital metal detection.

Digital balance control – levels temperature and humidity influences.

Auto calibration – fast and easy set-up.

Digital frequency & phase control avoid any drifts. Once calibrated keeps the set-up forever. No need for re-calibration.

Digital noise filters eliminate undesirable signals such as vibrations and shocks.

Multi-channel technology for the optimum recognition of all metals; ferrous, non-ferrous and stainless.

Power supply: Wide input 85–265 V AC works great even with unstable and poor power sources.

Auto self-control – possible functional defects of the device are displayed on a separate output contact.



### METAL SHARK® GF compact

Typically, the GF compact types are used in gravity feed pipes and provide high performance in detecting magnetic and non-magnetic metals. The bulk material fall through the metal detector. With the reject flap EX-S smallest metal objects are separated out of the goods' stream promptly.

The GF compact types have a low assembly height and are special designed for height limited installation locations. However, therefore the metal detecting performance is a little bit lower compared to the GF types.

With a maintenance free design and high quality construction, for reliable operation in the most challenging industrial environments.



### Easy handling

In practical use, settings of metal detectors often need to be checked quickly and reliably during production. Cassel attached great importance to user-friendliness: The software is self-explanatory: An interface-manager leads the user step by step through the menus that have to be adjusted. E.g. product teach is done with one-button-push.

### Intuitive operation

The display shows only the information that is really required. Reduction to the essential makes operation clear and transparent.

### Product library

The characteristics of 50 different products are stored and recalled here.

### Auto calibration

Provides simple and quick learning of product characteristics for product effect compensation. Pre-set product properties for DRY, WET, FROZEN, VIBRATION and SHOCK makes new product setting exceptionally easy and reliable.

### Operation History

Events such as metal detections or parameter settings are stored in a log list, including date and time and can be read on the display or exported via serial or ethernet link.

### Performance validation

According to HACCP the metal detector is a critical control point and therefore, it must be checked regularly. Optional check&catch gates in the pipeline allows to test the detector function regularly and easily. To this aim a metal embedded into a plastic ball is pushed through the pipe. Removable stainless steel grids, in the accept and reject pipes, allow the test metal to be easily recovered. The performance validation automatically prompts the operator to test the performance of the METAL SHARK® at pre-set intervals.

### High pressure washdown option

The METAL SHARK®'s electronics is installed inside a second SS enclosure. The aperture opening is longterm sealed and protected. The unit is suitable for daily steam-hose cleaning with max. 1000 psi. Sensor head and control unit exceed Ip67 (Nema 4x).



Application example

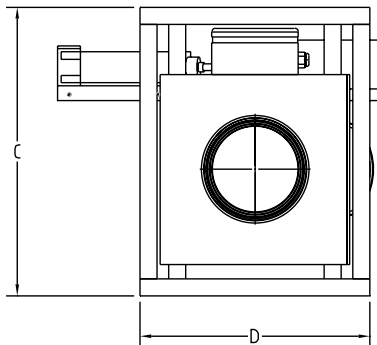
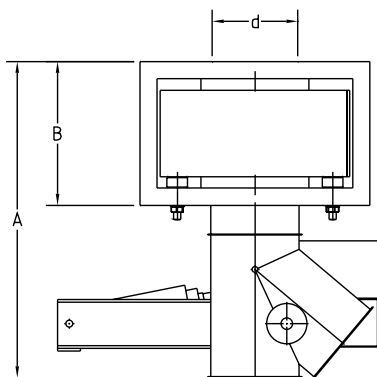

ø d	ø d (mm)	A	B	C	D	A (mm)	B (mm)	C (mm)	D (mm)	TYPICAL MATERIAL FLOW cu ft/hr	TYPICAL MATERIAL FLOW l/h	APPROXIMATE SENSITIVITY ømm		
												FE	Al	SS
4"	100	17,7"	7,9"	17,7"	12,5"	450	200	450	318	700	20000	0,7	1,0	1,1
5"	120	20,9"	9,8"	17,7"	13,3"	530	250	450	338	1000	28000	1,0	1,2	1,4
6"	150	23,6"	9,8"	19,8"	15,8"	600	250	502	400	1500	43000	1,1	1,5	1,8
8"	200	35,8"	11,8"	24,2"	20"	910	300	615	508	2600	74000	1,6	2,2	2,4
10"	250	41,3"	15,4"	31,5"	25,2"	1050	390	800	641	4000	115000	2,0	2,7	3,1
12"	300	43,1"	15,4"	37"	31,5"	1095	390	940	800	5800	165000	2,6	3,2	4,1